

**C-CHARGER**®  
MARINE ELECTRONIC BATTERY CHARGER

**INSTALLATION INSTRUCTIONS &  
OWNER'S MANUAL  
5000 SP Series**

# Contents

<b>INTRODUCING... THE SP SERIES C-CHARGER®</b> .....	<b>3</b>
Warranty/Registration .....	4
Manual Purpose .....	4
<b>IMPORTANT SAFETY INSTRUCTIONS</b> .....	<b>4</b>
Environmental Precaution .....	4
Application Precaution .....	4
Damaged Unit Precaution .....	4
Disassembly Precaution .....	4
Maintenance/Cleaning Precaution .....	5
Personal Safety Precautions .....	5
Preparing to Charge Precautions .....	5
Connecting to the Battery Outside the Boat Precautions .....	6
Grounding Precautions .....	6
<b>INSTALLING THE SP SERIES C-CHARGER®</b> .....	<b>6</b>
Verifying Proper Battery/Charger Type .....	6
Choosing Mounting Location .....	7
Choosing Mounting Hardware .....	7
Mounting the SP Series C-Charger® .....	7
Mounting the Splash Guard .....	7
Choosing Electrical Wiring Hardware .....	7
Choosing Wire Gauge .....	7
Making AC Connections on Terminal Block 1 (TB1) .....	9
Making DC Connections .....	9
Installing External Fuse (not supplied) .....	11
Closing the Cover .....	11
Applying Power .....	11
<b>OPERATING THE SP SERIES C-CHARGER®</b> .....	<b>12</b>
Proper Operation .....	12
Changing Internal Fuses .....	12
<b>MAINTAINING THE SP SERIES C-CHARGER®</b> .....	<b>12</b>
<b>TROUBLESHOOTING THE SP SERIES C-CHARGER®</b> .....	<b>12</b>
<b>WARRANTY &amp; CUSTOMER SERVICE</b> .....	<b>13</b>
Warranty .....	13
Warranty Service and Repair .....	13
Customer Service .....	14
<b>SPECIFICATIONS</b> .....	<b>14</b>

## INTRODUCING... THE SP SERIES C-CHARGER®

Thank you for purchasing the SP SERIES C-CHARGER®. Your SP series C-Charger represents the latest in electronic, pulse-modulated switching chargers. The SP series C-Chargers incorporate Charles Industries' new battery selector switch, that allows the use of currently available battery types (lead acid, gel cell and AGM). It is designed for hard-wired, on-board applications only. The SP series C-Charger converts AC shore power to DC charging current to maintain a selected battery type. The SP Series models charge up to three battery banks simultaneously. All of the SP series C-Charger units operate under a wide range of input voltages yet maintain a constant output, avoiding any danger of overcharging marine batteries. When necessary, the SP Series units are equipped with a cooling fan and an internal temperature compensation circuit that automatically adjusts to temperature variations, extending the life of the batteries. An external temperature compensation circuit is an available option (sold separately) on some models.

The various models available in the 5000 series C-Charger product offering are listed in Table 1.

**Table 1. SP Series C-Charger® Specifications**

Model Number	AC Input Voltage Range	AC Input Amps	DC Output Voltage	DC Output Amps	CE Listed	DIMENSIONS (L X W X H)	Approx Weight (Lbs)	Internal Replacement Fuse Size		Connection Reference
								AC	DC	
<b>12 Volt Units</b>										
93-12105SP-A	100-135V	4	12V	10		8 1/8 x 9 5/8 x 3 3/4	5.5	8A/250V*	30A/32V**	Figure 2
93-12155SP-A	100-135V	4	12V	15		8 1/8 x 9 5/8 x 3 3/4	5.5	8A/250V*	30A/32V**	Figure 2
93-12205SP-A	100-135V	5	12V	20		8 1/8 x 9 5/8 x 3 3/4	5.5	8A/250V*	30A/32V**	Figure 2
93-12305SP-A	100-135V	7	12V	30		10 1/2 x 9 5/8 x 3 3/4	7.5	10A/250V*	40A/32V**	Figure 3
93-12405SP-A	100-135V	9	12V	40		13 1/4 x 9 5/8 x 3 3/4	9	12A/250V*	(2)30A/32V**	Figure 3
93-12505SP-A	100-135V	11	12V	50		15 1/4 x 9 5/8 x 3 3/4	10.5	15A/250V*	(2)40A/32V**	Figure 3
9L-12505E-A	100-135V	11	12V	50		15 1/4 x 9 5/8 x 3 3/4	11	15A/250V*	(2)40A/32V**	Figure 3
93-12605SP-A	100-135V	13	12V	60		15 1/4 x 9 5/8 x 3 3/4	10.5	15A/250V*	(2)40A/32V**	Figure 3
9L-12605E-A	100-135V	13	12V	60		15 1/4 x 9 5/8 x 3 3/4	11	15A/250V*	(2)40A/32V**	Figure 3
93-12805SP-A	100-135V	20	12V	80		21 1/2 x 9 5/8 x 7/8	16.5	30A/250V*	100A/32V**	Figure 4
9L-12805E-A	100-135V	20	12V	80		21 1/2 x 9 5/8 x 7/8	16.5	30A/250V*	100A/32V**	Figure 4
93-121005SP-A	100-135V	20	12V	100		21 1/2 x 9 5/8 x 7/8	16.5	30A/250V*	100A/32V**	Figure 4
<b>24 Volt Units</b>										
9C-12105SPI-A	200-260V	2.5	12V	10	Yes	8 1/2 x 9 5/8 x 3 3/4	5.5	8A/250V*	30A/32V**	Figure 2
9C-12155SPI-A	200-260V	2.5	12V	15	Yes	8 1/2 x 9 5/8 x 3 3/4	5.5	8A/250V*	30A/32V**	Figure 2
9C-12205SPI-A	200-260V	3	12V	20	Yes	8 1/2 x 9 5/8 x 3 3/4	5.5	8A/250V*	30A/32V**	Figure 2
9C-12305SPI-A	200-260V	4	12V	30	Yes	10 1/2 x 9 5/8 x 3 3/4	7.5	10A/250V*	40A/32V**	Figure 3
9C-12405SPI-A	200-260V	5	12V	40	Yes	13 1/4 x 9 5/8 x 3 3/4	9.5	12A/250V*	(2)30A/32V**	Figure 3
9C-12505SPI-A	200-260V	6	12V	50	Yes	15 1/4 x 9 5/8 x 3 3/4	11	15A/250V*	(2)40A/32V**	Figure 3
9L-12505EI-A	200-260V	6	12V	50	Yes	15 1/4 x 9 5/8 x 3 3/4	11	15A/250V*	(2)40A/32V**	Figure 3
9C-12605SPI-A	200-260V	7	12V	60	Yes	15 1/4 x 9 5/8 x 3 3/4	11	15A/250V*	(2)40A/32V**	Figure 3
9L-12605EI-A	200-260V	7	12V	60	Yes	15 1/4 x 9 5/8 x 3 3/4	11	15A/250V*	(2)40A/32V**	Figure 3
9C-12805SPI-A	200-260V	10	12V	80	Yes	21 1/2 x 9 5/8 x 7/8	16.5	20A/250V*	100A/32V**	Figure 4
9L-12805EI-A	200-260V	10	12V	80	Yes	21 1/2 x 9 5/8 x 7/8	16.5	20A/250V*	100A/32V**	Figure 4
9C-121005SPI-A	200-260V	10	12V	100	Yes	21 1/2 x 9 5/8 x 7/8	16.5	20A/250V*	100A/32V**	Figure 4
<b>24 Volt Units</b>										
93-24105SP-A	100-135V	5	24V	10		10 1/2 x 9 5/8 x 3 3/4	7.5	10A/250V*	20A/32V**	Figure 2
93-24205SP-A	100-135V	9	24V	20		13 1/4 x 9 5/8 x 3 3/4	9.5	12A/250V*	30A/32V**	Figure 3
93-24305SP-A	100-135V	13	24V	30		15 1/4 x 9 5/8 x 3 3/4	11	15A/250V*	40A/32V**	Figure 3
93-24405SP-A	100-135V	16	24V	40		15 1/4 x 9 5/8 x 3 3/4	11	20A/250V*	(2)30A/32V**	Figure 3

Model Number	AC Input Voltage Range	AC In-put Amps	DC Output Voltage	DC Output Amps	CE Listed	DIMENSIONS (L X W X H)	Approx Weight (Lbs)	Internal Replacement Fuse Size		Connection Reference
								AC	DC	
<b>24 Volt Units</b>										
93-24505SP-A	100-135V	20	24V	50		21 1/2 x 9 5/8 x 3 7/8	16.5	30A/250V*	100A/32V**	Figure 4
93-24605SP-A	100-135V	20	24V	60		21 1/2 x 9 5/8 x 3 7/8	16.5	30A/250V*	100A/32V**	Figure 4
9C-24205SPI-A	200-260V	5	24V	20	Yes	13 1/4 x 9 5/8 x 3 3/4	9.5	12A/250V*	30A/32V**	Figure 3
9C-24305SPI-A	200-260V	6	24V	30	Yes	15 1/4 x 9 5/8 x 3 3/4	11	15A/250V*	40A/32V**	Figure 3
9C-24405SPI-A	200-260V	9.5	24V	40	Yes	15 1/4 x 9 5/8 x 3 3/4	11	20A/250V*	(2)30A/32V**	Figure 3
9C-24505SPI-A	200-260V	10	24V	50	Yes	21 1/2 x 9 5/8 x 3 7/8	16.5	20A/250V*	100A/32V**	Figure 4
9C-24605SPI-A	200-260V	10	24V	60	Yes	21 1/2 x 9 5/8 x 3 7/8	16.5	20A/250V*	100A/32V**	Figure 4
* SLO-BLO fuse										
**Fast-Acting fuse										

**Warranty/Registration**

Before proceeding, complete and mail back the Warranty Registration card.

**Manual Purpose**

With your personal safety in mind, this manual lists important safety precautions first, then covers installation, operation, maintenance, troubleshooting and warranty and customer service information.

**WARNING**

**RISK OF EXPLOSIVE GASES! WORKING IN THE VICINITY OF A LEAD ACID BATTERY IS DANGEROUS. BATTERIES GENERATE EXPLOSIVE GASES DURING NORMAL BATTERY OPERATION. THEREFORE IT IS OF UTMOST IMPORTANCE THAT EACH TIME BEFORE USING YOUR SP SERIES C-CHARGER YOU READ THIS MANUAL AND FOLLOW THE INSTRUCTIONS EXACTLY.**

**To reduce risk of battery explosion, follow these instructions, those of the battery manufacturer, and the manufacturer of any equipment you use in the vicinity of the battery. Review cautionary markings on these products and on the engine.**

**IMPORTANT SAFETY INSTRUCTIONS**

**SAVE THESE INSTRUCTIONS.** This manual contains important safety and operating instructions for the SP series C-Charger. Read the entire manual before usage. Also read all instructions and cautions for and on the SP series C-Charger and batteries.

**Environmental Precaution**

Do not expose the SP series C-Charger to rain, snow, or excessive moisture.

**Application Precaution**

These units are intended for hard-wired applications. Use of attachments not recommended or sold by Charles Marine Products may result in risk of fire, electrical shock or personal injury.

**Damaged Unit Precaution**

Do not operate the SP series C-Charger if it has received a sharp blow, been dropped, or otherwise damaged. See the section in this manual on *Warranty & Customer Service*.

**Disassembly Precaution**

Do not disassemble the SP series C-Charger. See the sections in this manual on *Maintaining the SP Series C-Charger, Troubleshooting the SP Series C-Charger and Warranty & Customer Service*.

## Maintenance/Cleaning Precaution

To reduce risk of electrical shock, disconnect the SP series C-Charger from AC power and batteries before attempting any maintenance or cleaning.

## Personal Safety Precautions

Adhere to the following personal safety precautions when installing or working with any of the 5000 SP series C-Chargers:

1. Someone should be within voice range or close enough to come to your aid when you work near a lead acid battery.
2. Have plenty of fresh water and soap nearby in case battery acid contacts skin, clothing, or eyes.
3. Wear complete eye protection and clothing protection. Avoid touching eyes while working near a battery.
4. If battery acid contacts skin or clothing, wash them immediately with soap and water. If acid enters the eye, flood the eye with cold, running water for at least ten minutes and get medical attention immediately.
5. Never smoke or allow a spark or flame in the vicinity of the battery or engine.
6. Do not drop a metal tool onto the battery. It may spark or short circuit the battery or other electrical parts that can cause an explosion.
7. Remove all personal metal items such as rings, bracelets, necklaces and watches when working near a lead acid battery. A battery can produce short circuit currents high enough to weld a ring or the like to metal, causing a severe burn.
8. The SP series C-Charger is not intended to supply power to a low voltage electrical system other than in a marine application. Do not use the SP series C-Charger for charging dry cell batteries that are commonly used with home appliances. These batteries may burst and cause personal injury and property damage.
9. **NEVER** charge a frozen battery.

## Preparing to Charge Precautions

### **CAUTION**

**To reduce risk of injury, refer to Figure 1 to insure that the proper cell type is selected. DO NOT attempt to charge multiple or non-recommended cell types. Other types of batteries may burst, causing personal injury and damage. When changing batteries from one cell type to another, refer to Figure 1 to select the proper battery type on the back of the unit.**

Before charging a battery with the SP series C-Charger, read the following precautions:

1. Make sure all accessories in the boat are off.
2. If the battery must be removed from the boat, always remove the grounded terminal from the battery first.
3. Be sure the area around the battery is well ventilated while the battery is being charged. Gas can be forcefully blown away using a piece of cardboard or other non-metallic material as a "hand fan".
4. Clean battery terminals. Be careful to keep corrosion from coming in contact with eyes.
5. Add distilled water in each cell until battery acid reaches levels specified by the battery manufacturer. This helps purge excessive gas from cells. Do not overfill. For a battery without cell caps, carefully follow the manufacturer's recharging instructions.
6. Study all battery manufacturer's precautions, such as removing or not removing cell caps while charging and recommended rates of charge.

### Connecting to the Battery Outside the Boat Precaution

The 5000 SP series C-Chargers have been specifically designed for hard-wired marine use inside a boat. They are not designed or equipped for charging batteries on shore or outside a boat.

### Grounding Precautions

When the SP series C-Charger is permanently mounted inside the boat, it must have a grounding conductor.

1. The SP series C-Charger should be connected to a metal, grounded, permanent wiring system. An equipment-grounding conductor should be run with the circuit wiring and connected through the SP series C-Charger housing grommets to the equipment grounding (GRN) terminal on the SP series C-Charger.
2. Connections to the SP series C-Charger should comply with all local codes and ordinances.

### **WARNING**

**External connections to the SP series C-Charger shall comply with the U.S. Coast Guard Electrical Regulations (33CFR183 subpart I).**

## INSTALLING THE SP SERIES C-CHARGER®

### Verifying Proper Battery/Charger Type

SP series C-Charger models may be used for charging LEAD ACID (wet/flooded), GEL CELL (gelled electrolyte) or AGM (absorbed glass mat) batteries. All SP series C-Chargers have been factory preset for GEL CELL batteries. To change the battery type of the SP series C-Charger model, refer to Figure 1.

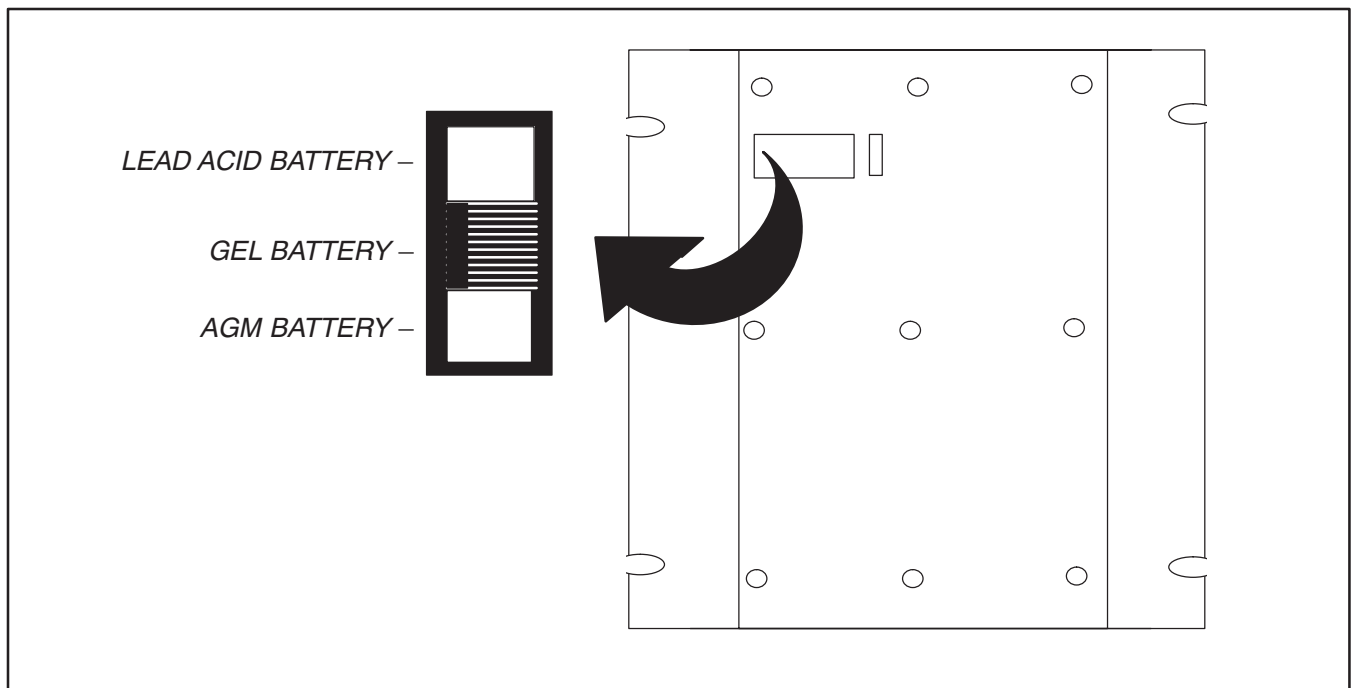

**Figure 1. Battery Type Selectable Switch (Bottom View)**

## Choosing Mounting Location

The SP series C-Charger should be mounted vertically flush on a bulkhead in a protected area away from rain or spray and as close to the batteries as possible. The SP series C-Charger is designed to operate in high ambient temperatures, with the proper ventilation. Six inches of unobstructed area on all sides of the unit should be allowed for air circulation and cooling.

*Note: The 30-, 40-, 50-, 60-, 80- and 100-amp. SP series C-Chargers are equipped with a cooling fan. The fan will start operation when the load is approximately 50% of the maximum rated output current. Also, a temperature compensation circuit exists to automatically adjust to room temperature variations. A temperature coefficient of 0.02VDC/°C for 12 volts or 0.04VDC/°C for 24 volts causes the output voltage of the SP series C-Charger to change inversely with the change in room temperature. The purpose of this circuit is to extend the life of the batteries.*

## Choosing Mounting Hardware

As with any marine equipment, secure mounting is of utmost importance. The bolts or screws used to secure the SP series C-Charger must be 1/4 inch in diameter, backed with a flat washer, and kept vibration-free with a split-ring lock washer. If using bolts, they must be long enough to be secured on both sides of the bulkhead. If using screws, they should be at least 1 inch long. All hardware should be corrosion-resistant.

## Mounting the SP Series C-Charger®

All corrosion-resistant mounting hardware should be readily available. Follow the steps below to mount the SP series C-Charger to the bulkhead.

Step	Action
1.	Hold the SP series C-Charger vertically flush on the bulkhead.
2.	Mark the mounting holes.
3.	Remove the SP series C-Charger.
4.	Drill the mounting holes.
5.	Insert one side of the mounting hardware half-way into the drilled mounting holes.
6.	Align the mounting slots on the SP series C-Charger with the secured hardware and slide the SP series C-Charger's mounting flange under the washers.
7.	Insert the mounting hardware for the other side.
8.	Secure all mounting hardware.

## Mounting the Splash Guard

Position and install the splash guard over the SP series C-Charger so that the back flange bottom rests on top of the SP series C-Charger. This insures proper vertical spacing for ventilation. For optimum splash protection, be sure to center the splash guard horizontally over the SP series C-Charger. Secure with 1/4-inch diameter screws, approximately 1/2 inch long.

## Choosing Electrical Wiring Hardware

The SP series C-Charger is intended for hard-wiring in a permanent application. Conduit or other appropriate marine electrical installation hardware should be used.

## Choosing Wire Gauge

Use Table 2 to determine the appropriate wire gauges. Avoid unnecessarily long runs of either AC or DC power lines.



**Before working on electrical equipment, first determine there is no live power! Double check power connections and all battery terminations.**

**WARNING**

**External connections to the SP series C-Charger shall comply with the U.S. Coast Guard Electrical Regulations (33CFR183 subpart I).**

**Table 2. Minimum Wire Sizes for SP Series C-Charger® Installation**

Model Number	AC Input			AC Torque Spec. (+/-1.0)	DC Output		DC Torque Spec
	25'	50'	100'		15'	25'	
<b>12 Volt Units</b>							
93-12105SP-A	18 AWG	18 AWG	14 AWG	8 inch-pounds	12 AWG	12 AWG	8 inch-pounds
93-12155SP-A	18 AWG	18 AWG	14 AWG	8 inch-pounds	12 AWG	12 AWG	8 inch-pounds
93-12205SP-A	18 AWG	16 AWG	14 AWG	8 inch-pounds	12 AWG	12 AWG	8 inch-pounds
93-12305SP-A	18 AWG	16 AWG	10 AWG	8 inch-pounds	10 AWG	8 AWG	16 inch-pounds
93-12405SP-A	16 AWG	14 AWG	10 AWG	8 inch-pounds	8 AWG	6 AWG	16 inch-pounds
93-12505SP-A	16 AWG	12 AWG	10 AWG	8 inch-pounds	6 AWG	6 AWG	16 inch-pounds
9L-12505E-A	16 AWG	12 AWG	10 AWG	8 inch-pounds	6 AWG	6 AWG	16 inch-pounds
93-12605SP-A	14 AWG	12 AWG	10 AWG	8 inch-pounds	6 AWG	6 AWG	16 inch-pounds
9L-12605E-A	14 AWG	12 AWG	10 AWG	8 inch-pounds	6 AWG	6 AWG	16 inch-pounds
93-12805SP-A	14 AWG	12 AWG	10 AWG	8 inch-pounds	4 AWG	2 AWG	35 inch-pounds
9L-12805E-A	14 AWG	12 AWG	10 AWG	8 inch-pounds	4 AWG	2 AWG	35 inch-pounds
93-121005SP-A	12 AWG	12 AWG	10 AWG	8 inch-pounds	2 AWG	2 AWG	35 inch-pounds
9C-12105SPI-A	18 AWG	18 AWG	16 AWG	8 inch-pounds	12 AWG	12 AWG	8 inch-pounds
9C-12155SPI-A	18 AWG	18 AWG	16 AWG	8 inch-pounds	12 AWG	12 AWG	8 inch-pounds
9C-12205SPI-A	18 AWG	18 AWG	16 AWG	8 inch-pounds	12 AWG	12 AWG	8 inch-pounds
9C-12305SPI-A	18 AWG	18 AWG	16 AWG	8 inch-pounds	10 AWG	8 AWG	16 inch-pounds
9C-12405SPI-A	18 AWG	16 AWG	14 AWG	8 inch-pounds	8 AWG	6 AWG	16 inch-pounds
9C-12505SPI-A	18 AWG	16 AWG	12 AWG	8 inch-pounds	6 AWG	6 AWG	16 inch-pounds
9L-12505EI-A	18 AWG	16 AWG	12 AWG	8 inch-pounds	6 AWG	6 AWG	16 inch-pounds
9C-12605SPI-A	16 AWG	14 AWG	12 AWG	8 inch-pounds	6 AWG	6 AWG	16 inch-pounds
9L-12605EI-A	16 AWG	14 AWG	12 AWG	8 inch-pounds	6 AWG	6 AWG	16 inch-pounds
9C-12805SPI-A	16 AWG	14 AWG	10 AWG	8 inch-pounds	4 AWG	2 AWG	35 inch-pounds
9L-12805EI-A	16 AWG	14 AWG	10 AWG	8 inch-pounds	4 AWG	2 AWG	35 inch-pounds
9C-121005SPI-A	16 AWG	14 AWG	10 AWG	8 inch-pounds	2 AWG	2 AWG	35 inch-pounds
<b>24 Volt Units</b>							
93-24105SP-A	18 AWG	16 AWG	12 AWG	8 inch-pounds	12 AWG	12 AWG	8 inch-pounds
93-24205SP-A	16 AWG	14 AWG	10 AWG	8 inch-pounds	12 AWG	12 AWG	16 inch-pounds
93-24305SP-A	14 AWG	12 AWG	10 AWG	8 inch-pounds	10 AWG	10 AWG	16 inch-pounds
93-24405SP-A	14 AWG	12 AWG	10 AWG	8 inch-pounds	8 AWG	6 AWG	16 inch-pounds
93-24505SP-A	12 AWG	12 AWG	10 AWG	8 inch-pounds	8 AWG	6 AWG	35 inch-pounds
93-24605SP-A	12 AWG	12 AWG	10 AWG	8 inch-pounds	8 AWG	6 AWG	35 inch-pounds
9C-24205SPI-A	18 AWG	16 AWG	14 AWG	8 inch-pounds	12 AWG	12 AWG	16 inch-pounds
9C-24305SPI-A	16 AWG	14 AWG	12 AWG	8 inch-pounds	10 AWG	10 AWG	16 inch-pounds

Model Number	AC Input			AC Torque Spec. (+/-1.0)	DC Output		DC Torque Spec
	25'	50'	100'		15'	25'	
9C-24405SPI-A	16 AWG	14 AWG	12 AWG	8 inch-pounds	8 AWG	6 AWG	16 inch-pounds
9C-24505SPI-A	16 AWG	14 AWG	10 AWG	8 inch-pounds	8 AWG	6 AWG	35 inch-pounds
9C-24605SPI-A	16 AWG	14 AWG	10 AWG	8 inch-pounds	8 AWG	6 AWG	35 inch-pounds

### Making AC Connections on Terminal Block 1 (TB1)

After determining the wire lengths and gauges, make the AC wiring connections to TB1. (Refer to the figure number indicated in Table 1 for your model.) Use captive spade or ring terminals, and torque the screws to 8 +/-1 inch/pounds.

To make connections to the terminal blocks:

Step	Action
1.	Gently slide the cover off.
2.	Bring the AC input wires in through the left side access hole on the bottom of the unit.
3.	Connect the WHT terminal to the white (neutral) input. When installing a 9C-xxxxxSPI-A charger for domestic application, use the neutral terminal as the second high-voltage input.
4.	Connect the BLK terminal to the black (hot) AC input
5.	Connect the GRN terminal to the green (ground) input.



**DANGER**

**Do not operate this unit without the green wire connected to the SP series C-Charger and to suitable ground at shore connection.**

*Note: Read this manual and all precautions before installing or making connections!*

### Making DC Connections

After the appropriate wire lengths and gauges have been determined, make the DC connections to TB2. (Route the DC wire through the right-side access hole on the bottom of the unit.) Use captive spade or ring terminals when necessary, and torque the DC connections to the specifications listed in Table 2. The SP series output connections consist of three positive (+) terminals for up to three battery banks. One negative (-) terminal is provided that is common for all battery banks.

#### **WARNING**

**In accordance with ABYC E-11, a fuse or circuit breaker must be placed within 72 inches of the point of connection to the batteries or its bus on all positive output conductors. Also see Coast Guard Reg. 33CFR183 subpart I.**

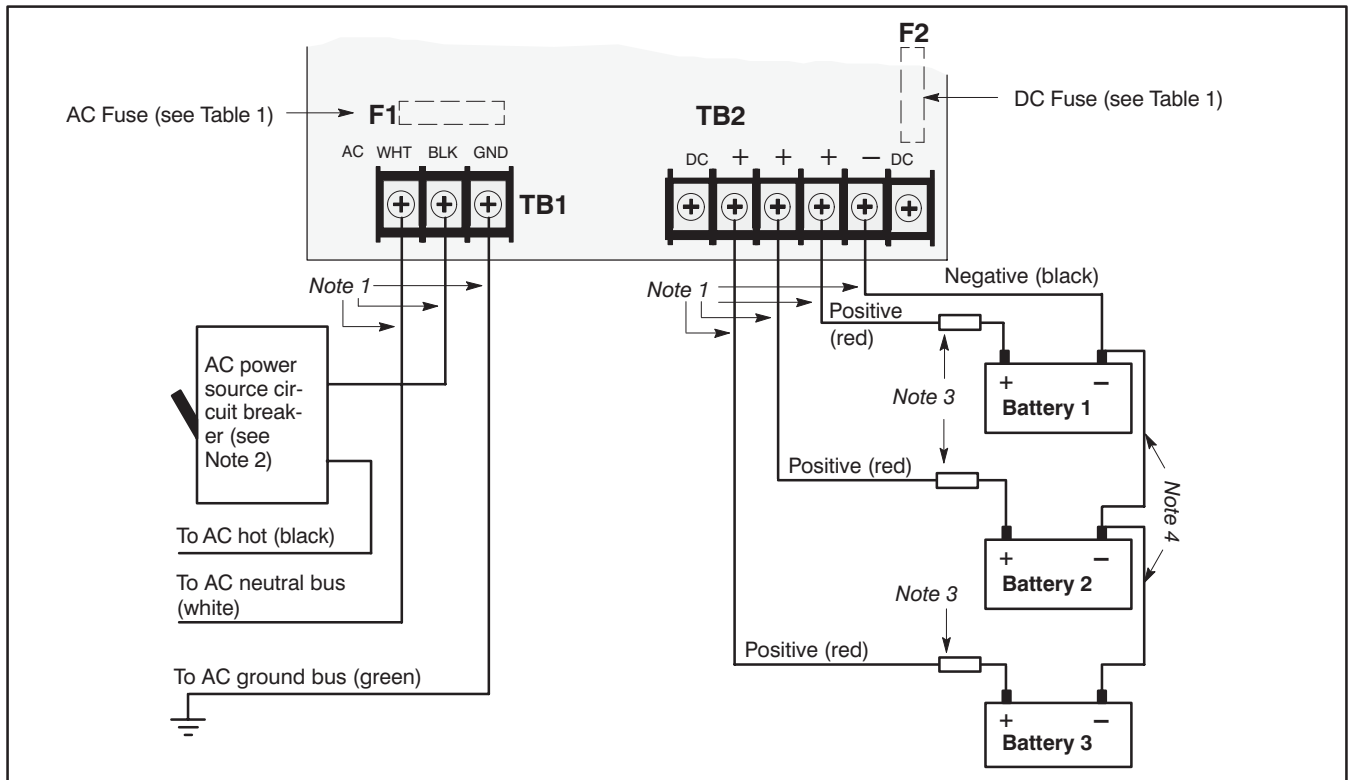

**Figure 2. Wiring Diagram (Reference Table 1 for Applicable SP Series C-Charger Model)**

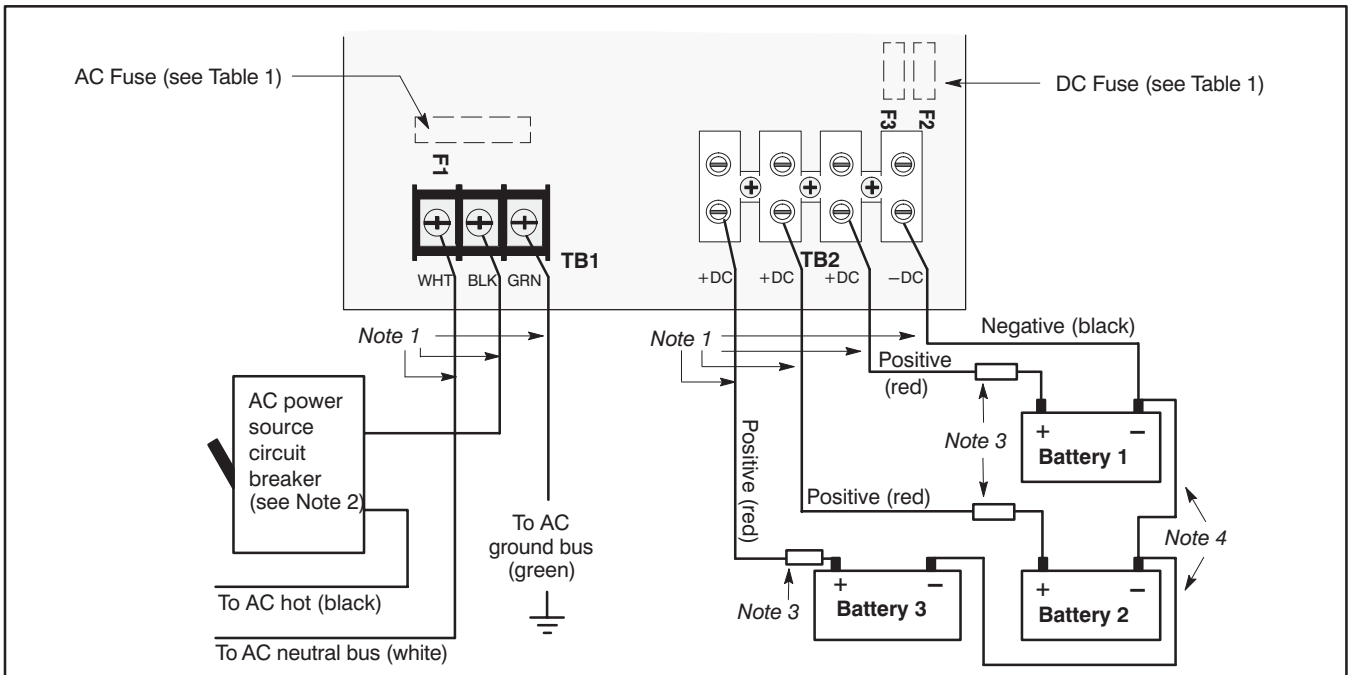

**Figure 3. Wiring Diagram (Reference Table 1 for Applicable SP Series C-Charger Model)**

**Notes:**

1. AC wiring and DC wiring (see Table 2).
2. AC circuit breaker should be sized as closely as possible to the rated AC input amperage (see Table 1).
3. DC fuse/circuit breaker installation—ABYC standards require a fuse or circuit breaker to be placed within 7 inches of the battery on all positive conductors, or within 72 inches of the battery if entire cable length is enclosed in a conduit. Fuses/circuit breakers must be sized 120–150% of the unit’s output amperage, but no greater than 150% of the rating of the conductor.
4. Black jumper (common negative) - only necessary if batteries are not pre-wired with common negative.

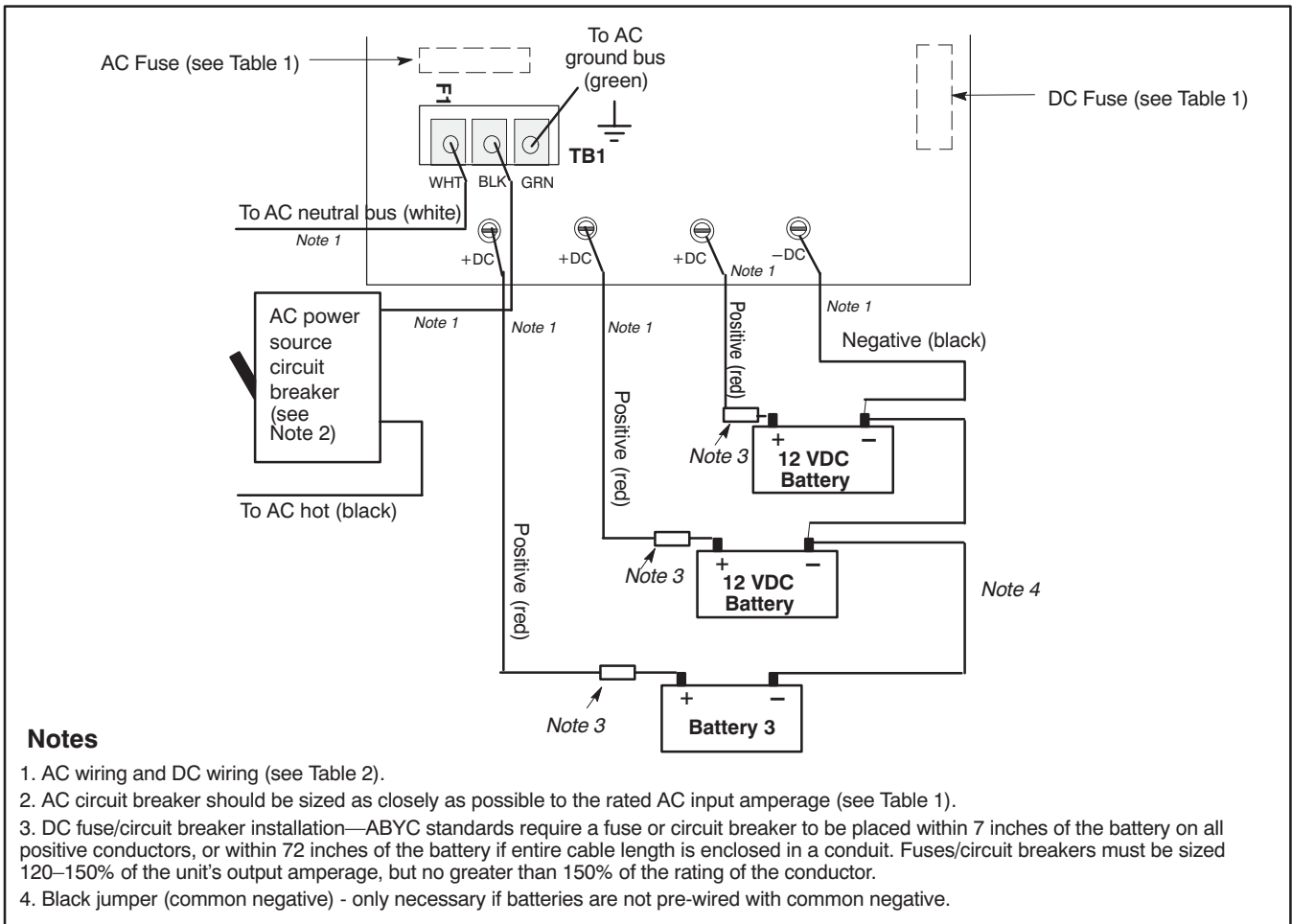

**Figure 4. Wiring Diagram (Reference Table 1 for Applicable SP Series C-Charger Model)**

**Installing External Fuse (not supplied)**

A fuse or circuit breaker (not provided) must be installed within 7 inches of the battery on all positive (+) conductors, or within 72 inches of the battery if the entire cable length is enclosed in a conduit. Fuses/circuit breakers must be sized 120% to 150% of the unit's output amperage (Table 1) but no greater than 150% of the rating of the conductor. See figures 1, 2 or 3, Note 3 for the location of this external fuse or circuit breaker.

**Closing the Cover**

Before closing the cover, make sure that all electrical connections have been properly made at all the battery banks (most important) and at the SP series C-Charger. Also check that all wiring is properly dressed with no exposed, bare wires.

**Applying Power**

Step	Action
1.	Apply shore power to the unit and turn on the AC power source circuit breaker.
2.	Check the front-panel ammeter for movement. A substantial movement in a clockwise direction indicates the batteries need a charge (there should be a slight movement even if the batteries are charged). If a counterclockwise movement occurs, turn off power immediately and refer to Table 4.

If the SP series C-Charger does not charge batteries or perform as described, refer to the section in this manual on *Troubleshooting the SP Series C-Charger*.

## OPERATING THE SP SERIES C-CHARGER®

Always follow all precautions in the *IMPORTANT SAFETY INSTRUCTIONS* section in this manual.

### Proper Operation

When properly installed and connected, the SP series C-Charger will automatically charge and maintain the batteries. When power is applied, the SP series C-Charger will enter a bulk or “constant current” mode, during which a higher rate of charge is achieved to fully replenish the batteries. When the batteries near a full charge, the output current will decrease and the charger will enter a timed absorption mode. After four hours in absorption mode, the output will drop to a float rate to maintain the batteries at a temperature compensated finishing voltage (13.6 VDC @ 25°C for lead acid). Refer to Table 3 for charge voltages.

**Table 3. Charge Voltages**

Charge Voltage (bulk)	Battery Type	Charge Voltage (float)
14.5 volts	Lead Acid (Wet/Flooded)	13.6 volts
14.2 volts	Gel Cell (Gelled Electrolyte)	13.6 volts
14.2 volts	AGM (Absorbed Glass Mat)	13.4 volts

### Changing Internal Fuses

Irregular conditions or loads may cause one or more of the internal fuses to blow. ALWAYS determine there is no live power before replacing a fuse.

Step	Action
1.	Remove the cover.
2.	The AC fuse (F1) is located just above the AC terminal block (TB1) and the DC fuses (F2 and F3) are located above the DC output connections (see Figures 1, 2 and 3). When replacing fuses, use only fuses of exactly the same type and rating (See Table 1).
3.	Replace and secure the cover.
4.	Reapply power.

## MAINTAINING THE SP SERIES C-CHARGER®

There are no adjustment or maintenance requirements for the SP series C-Charger other than cleaning the outside cabinet with a dry cloth. Periodically have all connections checked by a qualified service person, especially if the boat is operated in heavy, pounding seas.

### CAUTION

**For lead acid batteries check battery water levels frequently, especially if the boat is at dock for extended periods of time. Low water levels will damage batteries!**

## TROUBLESHOOTING THE SP SERIES C-CHARGER®

If there is a problem with the SP series C-Charger, first check all connections and retest. If all connections are good, see if the problem is covered in Table 4. If the problem is not covered in Table 4, or if the SP series C-Charger still malfunctions after performing the solution given, contact Charles Marine Products for technical assistance.

**Table 4. Troubleshooting Suggestions**

<b>Condition</b>	<b>Solution</b>
Not clear if batteries are fully charged.	As the batteries charge, the ammeter gradually falls. When it reads zero, the batteries are fully charged.
It takes too long to charge batteries.	The SP series C-Charger brings a discharged battery voltage level up slowly to avoid shortening the life of the battery. The recharge time depends on the degree of discharge.
Unable to identify if lack of battery charge is due to a battery problem or an SP series C-Charger problem.	<p>When the ammeter reads zero, test the condition of a battery by first turning off the AC power source to the SP series C-Charger, and disconnecting the battery from the SP series C-Charger for at least one hour. Connect battery to an ohm-volt meter. A reading of 12.6 VDC or more is desirable. A reading between 12.4 and 12.6 indicates a charge between 75 and 100%. A reading between 12.2 and 12.4 VDC indicates a charge between 50 and 75%. Consult the battery manufacturer's Owner's Manual for instructions.</p> <p>If it appears the battery is operating properly, proceed to check the following only after reading and fully understanding all safety instructions listed in this manual. Check input voltage at 120 VAC, check the SP series C-Charger's AC fuse and DC fuse, check the battery fuse/AC circuit breaker (Figure 1, Note 3) and check all associated wiring connections. If these appear to be working, the SP series C-Charger's DC output can be tested by turning off all AC power to the unit and then disconnecting all DC outputs from the charger. Upon reapplying AC power, the DC voltage between any (+) and (-) output connection should be between 13.5 and 15 VDC. Should the unit still be inoperable after all tests have been completed in sequence, refer to the section in this manual on <i>Warranty &amp; Customer Service</i>.</p>
The ammeter deflects in a counterclockwise direction.	Disconnect the unit immediately. Examine wiring instructions again to assure proper connections. A movement in a counterclockwise direction or a full-scale movement indicates excessive current. A wiring error is suspected. A voltmeter can monitor the voltage at the battery when the SP series C-Charger is turned on. An increase in voltage should occur as power is applied.
Internal red LED on.	The unit is at half-power because the ambient air is too hot. The unit may be at half-power because the fans are not working. Full power will be restored when the temperature returns to normal.

## WARRANTY & CUSTOMER SERVICE

### Warranty

CHARLES Marine & Industrial warrants the SP series C-Charger® will be free from defects in materials and workmanship that cause mechanical failure for five (5) years, as set forth in the Limited Warranty. Review this warranty carefully for information on what is covered by its terms. Complete and return the warranty registration card within ten (10) days of purchase to establish proof of ownership and validate the warranty coverage. You must provide notice of any alleged defect in material or workmanship within thirty (30) days of discovering the problem, and within the warranty period. Follow the procedure outlined below to obtain warranty service.

### Warranty Service and Repair

If the unit fails to operate properly after following all the instructions in the manual, or if the SP series C-Charger requires service, take the following steps:

1. Contact Charles Marine & Industrial Group Customer Service and obtain a "Returned Materials Authorization" (RMA) number and a Service Center address
2. Ship or mail the SP series C-Charger together with the RMA to the appropriate Service Center. Shipping costs to and from the Service Center are your responsibility
3. When service is complete, the Service Center will return the SP series C-Charger to you.

**Customer Service**

If technical assistance or customer service is needed, contact Charles Marine & Industrial Group (Monday through Friday, 7:00 AM to 5:00 PM Central Time) at:

800/830-6523 (Customer Service)

217/932-2473 (FAX)

*For correspondence only:*

Corporate

Headquarters: Charles Industries, Ltd.  
 Marine & Industrial Group  
 5600 Apollo Drive  
 Rolling Meadows, IL 60008-4049  
 USA  
 www.charlesindustries.com

Service &

Repair Center: Charles Industries, Ltd.  
 Marine & Industrial Group  
 400 S.E. 8th Street  
 Casey, IL 62420-2054  
 USA

**SPECIFICATIONS**

The specifications for the 5000 SP series C-Charger are listed in Table 1.

